



# Pro Series C11

## Combination Primary and Backup Sump Pump System

### PAIR OF PUMPS

### Instruction Manual & Safety Warnings

#### Table of Contents

<b>Important Safety Warnings and Instructions</b>		<b>Understanding the Warning Lights and Alarms</b>	
Electrical precautions	1	Silencing the alarm during an emergency	7
Battery preparation	1	Power alarm	7
Battery precautions	1	Battery fluid low	7
<b>Introduction</b>		Refilling the battery	7
Items included in system	2	Pump was activated	8
Additional items needed	2	Replacing the backup pump	8,9
System specifications	2	Replacing the primary pump	10,11
<b>Installing the Pipe and Pump</b>	3	System operating	11
<b>Battery Instructions</b>	4,5	Battery corroded or defective	11
<b>System Connections</b>		Cleaning battery terminals	12
Mounting the control unit	5	Replacing the battery	12,13
Connecting the backup pump	5	Test-reset button	13
Installing the battery fluid sensor	5	<b>Testing the System</b>	
Connecting the battery	6	Testing the backup float switch	13
Connecting the charger	6	Testing the primary float switch	13,14
Connecting the primary pump	6	<b>Maintenance Check List</b>	14
<b>Battery Maintenance</b>	6	<b>Parts &amp; Service Information</b>	
<b>Product Operation</b>		Technical support	14
Float switches	6	<b>Replacement Parts Diagram &amp; List</b>	15
1/8" weep holes	6	<b>Troubleshooting Guide</b>	16
Controllers	6	<b>Warranty</b>	17



## Important Safety Warnings & Instructions

**SAVE THESE INSTRUCTIONS.** This manual contains important SAFETY WARNINGS and OPERATING INSTRUCTIONS for the Pro Series combination sump pump system. You will need to refer to it before attempting any installation or maintenance. **ALWAYS** keep these instructions with the unit so that they will be easily accessible.

Failure to read and follow these warnings and instructions could result in property damage, serious injury, or death. It is important to read this manual, even if you did not install the Pro Series combination sump pump system, since this manual contains safety information regarding the use and maintenance of this product. **DO NOT DISCARD THIS MANUAL.**

### ELECTRICAL PRECAUTIONS

#### **⚠ WARNING**

This installation must be in accordance with the National Electric Code and all applicable local codes and ordinances.

#### **⚠ DANGER**

Risk of electrical shock and fire hazard. May result in death, serious injury, shock or burns. To help reduce these risks, observe the following precautions:

- **DO NOT** walk on wet areas of the basement until all power has been turned off. If the main power supply is in a wet basement, call an electrician.
- **ALWAYS** disconnect the pumps from the power source before servicing or making adjustments.
- **ALWAYS** unplug the control units and disconnect the cables from the battery before attempting any maintenance or cleaning.
- **NEVER** handle the pump or control unit with wet hands or when standing on a wet or damp surface while the pump is plugged into the power source.
- **MAKE SURE THERE IS A PROPERLY GROUNDED RECEPTACLE AVAILABLE.** This pump is wired with a 3-prong grounded plug. To reduce the risk of electric shock, be certain that it is only connected to a properly grounded 3-prong receptacle. If you have a 2-prong receptacle, have a licensed electrician

replace it with a 3-prong receptacle according to local codes and ordinances.

- **NEVER** bypass grounding wires or remove the ground prong from the plug.
- **DO NOT** use an extension cord. The electrical outlet should be within the length of the pump's power cord, and at least 4 feet above the floor level to minimize potential hazards from flood conditions.
- **DO** protect the electrical cord from sharp objects, hot surfaces, oil and chemicals. Avoid kinking the cord.
- **MAKE SURE** the supply circuit has a dedicated fuse or circuit breaker rated to handle the power requirements noted on the nameplate of the pump.

#### **CAUTION**

To reduce the risk of hazards that can cause injury or property damage, observe the following precautions:

- **DO NOT** use the power cord or strain relief to carry the pumps. Use the handle.
- **DO NOT** pull on the cord to disconnect the system or the pump. Pull the plug.
- **DO NOT** expose the control units to moisture, rain or snow.
- **DO NOT** operate the pumps or control units if they have been damaged in any way.
- **DO NOT** use pumps in pits handling raw sewage, salt water, or hazardous liquids. This product is rated for ground water use only.
- **DO NOT** disassemble the pumps or control units. When service is required, contact Glentronics' technical support at 800-991-0466. Return the product to the manufacturer for any repairs at the following address:

Glentronics, Inc.

645 Heathrow Drive, Lincolnshire, IL 60069

### BATTERY PREPARATION

#### **⚠ WARNING / POISON**

Sulfuric acid can cause blindness or severe burns. Avoid contact with skin, eyes or clothing. In the event of accident, flush with water and call a physician immediately. **KEEP OUT OF REACH OF CHILDREN.**

To help reduce these risks, observe the following precautions:

- Someone should be within range of your voice or close enough to come to your aid when you work near a lead-acid battery.
- Have plenty of fresh water and soap nearby in case battery acid contacts skin, clothing or eyes.
- Wear eye and clothing protection and avoid touching your eyes while working with battery acid or working near the battery.
- If battery acid contacts skin or clothing, wash immediately with soap and water. If acid enters eye, immediately flood eye with running cold water for at least 15 minutes and get prompt medical attention.
- Battery posts and terminals contain lead, lead compounds or chemicals known to the State of California to cause cancer, birth defects or other reproductive harm. Wash hands after handling. See <https://www.p65warnings.ca.gov/> for more information.

### BATTERY PRECAUTIONS

#### **⚠ DANGER**

Explosive gases could cause serious injury or death. Cigarettes, flames or sparks could cause battery to explode in enclosed spaces. Charge in well-ventilated area. Always shield eyes and face from battery. Keep vent caps tight and level.

To help reduce these risks, observe the following precautions:

- **NEVER** smoke or allow a spark or flame in the vicinity of the battery.
- Use the Pro Series control unit for charging a LEAD-ACID battery only. **DO NOT** use the control unit for charging dry-cell batteries that are most commonly used with home appliances.
- Be sure the area around the battery is well-ventilated.
- When cleaning or adding water to the battery, first fan the top of the battery with a piece of cardboard or another non-metallic material to blow away any hydrogen or oxygen gas that may have been emitted from the battery.
- **DO NOT** drop a metal tool onto the battery. It might spark or short-circuit the battery and cause an explosion.

- Remove personal metal items such as rings, bracelets, watches, etc. when working with a lead-acid battery. A short circuit through one of these items can melt it causing a severe burn.
- **ALWAYS** remove the charger from the electrical outlet before connecting or disconnecting the battery cables. *Never allow the rings to touch each other.*
- Check the polarity of the battery posts. The POSITIVE (+) battery post usually has a larger diameter than the NEGATIVE (-) post.



POSITIVE POST HAS LARGER DIAMETER



NEGATIVE POST HAS SMALLER DIAMETER

- When connecting the battery cables, first connect the small ring on the end of the WHITE wire to the NEGATIVE (-) post of the battery, and then connect the large ring on end of the BLACK wire to the POSITIVE (+) post of the battery.

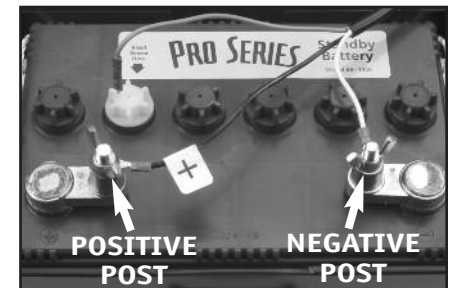

#### **⚠ DANGER**

Do not use system to pump flammable or explosive fluids such as gasoline, fuel oil, kerosene, etc. This product is rated for ground water use only.

## Introduction

The Pro Series Pair of Pumps combination system is designed to provide both primary and backup pumping capabilities. The primary pump will operate as long as it is receiving AC power. If the power is interrupted, or more water is coming into the sump than the AC pump can handle, the backup sump pump will begin pumping automatically. The backup system has unique monitoring features that diagnose a problem and sound an alarm. A light on the display panel of the control unit will indicate the cause of the alarm and the corrective action. The two systems have been pre-assembled for easy installation.

For added reliability, the float switches have, not one, but two floats. Should one float fail to operate, the second float automatically activates the pump.

### The Pair of Pumps Combination Sump Pump System includes:

- A 1/3 HP primary pump with a caged dual float switch, and a blue piggyback controller that plugs into the wall outlet
- A blue backup pump
- A black control unit with a battery fluid sensor, a dual float switch, and battery cables
- A battery charger
- A battery cap with a hole to accommodate the fluid sensor
- A battery box
- A no hub coupling

### You will also need to supply:

- A PHCC Pro Series B-1000, B-2200 or B12-90 standby battery



- A surge protector (recommended)
- Six (6) quarts of 1.265 specific gravity battery acid

**DO NOT** use an automotive battery with this system

The internal construction of some wet cell or maintenance free (AGM) batteries may not be compatible with this system. Glentronics, Inc. cannot guarantee the compatibility of other brands of batteries. The use of a PHCC Pro Series battery is **HIGHLY** recommended.



**For some installations you may need additional items:**

- 1-1/2" rigid PVC pipe to connect to the existing plumbing
- A PVC pipe connector or a rubber union
- PVC pipe cleaner and cement



## System Specifications

Power supply requirements.....115 volts, 60 Hz  
 AC pump pumping capacity..... 2770 GPH @ 10'  
 ..... 46 GPM @ 10'  
 DC pump pumping capacity..... 1000 GPH @ 10'  
 ..... 17 GPM @ 10'  
 Overall dimensions..... 11" W x 23 3/4" H

## Installing the Pipe and Pump

The Pro Series Pair of Pumps combination system is compact and will fit in a sump pit as small as 12" wide. It measures 23 3/4" inches from the bottom of the pump stand to the top of the Y-connector where it will be attached to the discharge pipe.

Use a pit that conforms to all local codes, and check the code to see if a gate valve or ball valve is required.

The path of the existing vertical discharge pipe to an exterior wall should have the shortest path with the fewest turns. The more turns will reduce the pumping capacity. The horizontal discharge pipe must be positioned in a downward slope when it exits the building, so any remaining water will drain away. Failure to do this will prevent water from exiting the pit, and damage the pump if the line freezes. (see Diagram A)

The system should be placed on a flat surface free

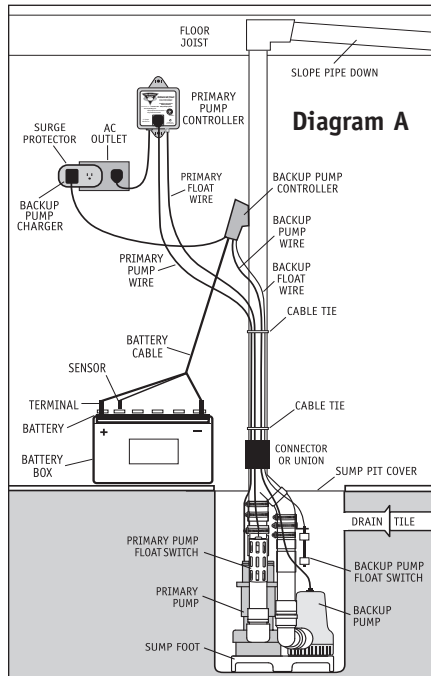

from dirt and debris. If the bottom of the sump pit is not clean, remove as much of the debris as possible. The pumps are attached to a sump foot (stand) to raise them above any debris.

If you are replacing an old sump pump, **unplug the pump from the outlet.**

1. Remove the check valve or rubber union. **Discard the check valve. The Pro Series system contains built-in check valves, so the old check valve will not be needed.** If the existing system is installed without a check valve or rubber union, saw the pipe apart above the sump pit. (Refer to the diagram in step 3)
2. Remove the old pump from the pit, and unscrew the pipe and pipe adapter from the pump. You can use this pipe for the rest of the installation.
3. Measure the distance from the bottom of the sump pit to the end of the discharge pipe. Subtract 24 3/4" inches (the height of the pump system + 1 inch). Cut a piece of 1-1/2" rigid PVC pipe to that length.
4. (a) Connect this piece to the discharge pipe by cementing the two pieces together with a 1-1/2" PVC pipe connector. (Follow the instructions on the PVC pipe cleaner and cement.) OR, (b) connect the two pieces of pipe together with a no hub coupling.
5. Remove the attached cords and controllers from the carton and place them next to the pump system. **BE SURE THE CORDS AND CONTROLLERS DO NOT FALL INTO THE SUMP PIT.**
6. Loosen the hose clamps on the no hub coupling and slide the coupling up on the discharge pipe. Tighten the upper hose clamp.
7. Lift the combination system by the handle on the primary pump and lower it into the sump pit. Make sure it is level.
8. Inspect the two float switches. They should both be vertical.
9. Inspect all of the screws on the hose clamps of the no hub couplings (primary and backup pumps). They should be tight.
10. Position the top of the pump system pipe so

that it is directly below the discharge pipe. Connect the system with the no hub coupling, and tighten the upper and lower hose clamps. Make sure both the discharge pipe and the system have ample overlap within the no hub coupling.

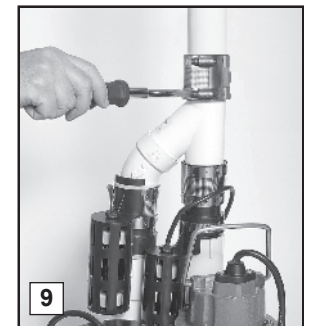
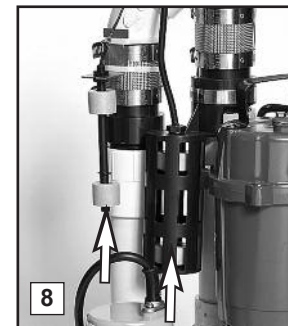
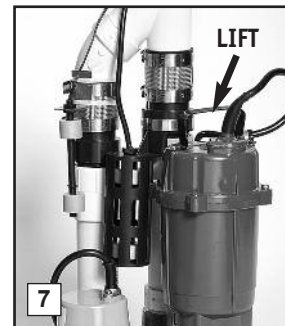
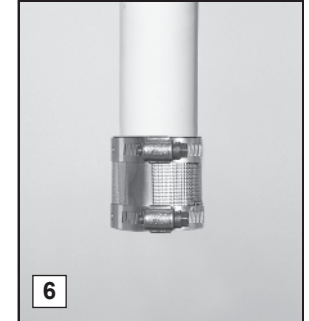
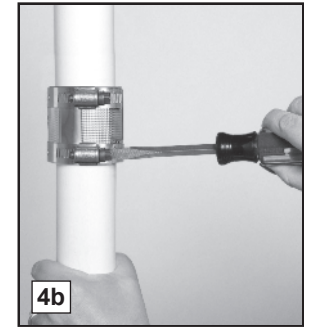
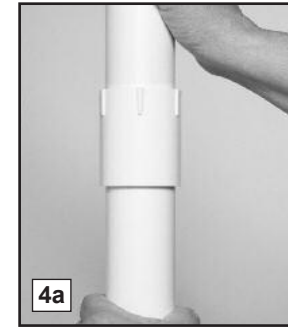
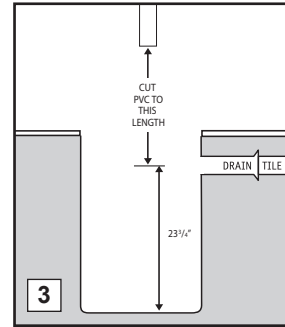
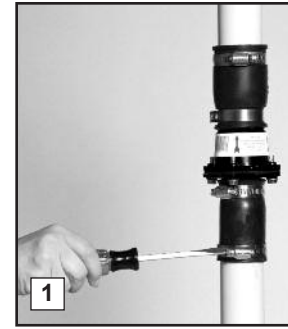

## Battery Instructions

The PHCC Pro Series B-1000 Standby Battery has been designed to run this system for a minimum of 50 hours, based on a 10% duty cycle. However, most of the time the pump will turn on and off, and the battery will run the pump intermittently for days. In addition, the unique materials in the battery enable it to last longer in standby service. The PHCC-1000 battery backup system will also accommodate the PHCC Pro Series B12-90 maintenance free (AGM) battery. To extend the run time of the pump, use the PHCC Pro Series B-2200 Standby Battery or B12-90 maintenance free (AGM) battery.

*Note: The battery will not run the primary pump.*

### CAUTION

- The use of automotive batteries is NOT recommended. Automotive batteries are not designed for this application. They will only run the pump for a short time and will have a shorter life than a standby battery.
- The battery fluid sensor is designed to fit the Pro Series Standby batteries. Measuring the battery fluid is one of the most important features of the system, since about 80% of backup sump pump failures are the result of a battery that has dried out.
- The internal construction of some batteries may not be compatible with this system. Glentronics, Inc. can not guarantee the compatibility of other brands of batteries. The use of a PHCC Pro Series battery is HIGHLY recommended.

### ⚠ DANGER

DO NOT insert the fluid sensor into any battery except a PHCC Pro Series battery (B-1000 or B-2200). DO NOT use the enclosed battery cap on any battery except a PHCC Pro Series B-1000 or B-2200 battery. DO NOT drill a hole in the cap or the top of another brand of battery to accommodate the fluid sensor. Batteries emit explosive gases, which can cause serious injury or death.

### PREPARING THE PRO SERIES STANDBY BATTERY

The Pro Series Standby batteries are shipped dry (without acid) so they never lose power before you take them home. A battery is activated when the acid is added, and then it slowly begins to deteriorate as it ages. By adding the

acid just before use, the battery will always be fresh. Use 1.265 specific gravity battery acid to fill the battery. It is available where you purchased the battery.

*NOTE: Pro Series batteries now come in two configurations. The tops of the batteries look different, and the directions for filling the batteries and connecting the fluid sensor will vary slightly. Instructions for both batteries follow. If the top of your battery looks like the photo of BATTERY A, follow the instructions on this page. If the top of your battery looks like the photo of BATTERY B, follow the instructions on page 5.*

### ⚠ DANGER/POISON

Contains sulfuric acid. Wear eye and clothing protection. If battery acid contacts skin or clothing, wash immediately with soap and water. If acid enters eyes, flush with water for 15 minutes, and get prompt medical attention. Review the safety instructions on page 1.

### TO FILL THE BATTERY

1. Place the battery box on the floor. Place the dry (unfilled) battery into the battery box.
2. Remove the foil seal on the top of the battery.
3. Carefully push in the perforated tab at the top of the acid pack. Lift up the large tab and pull out the dispensing hose. Hold the hose

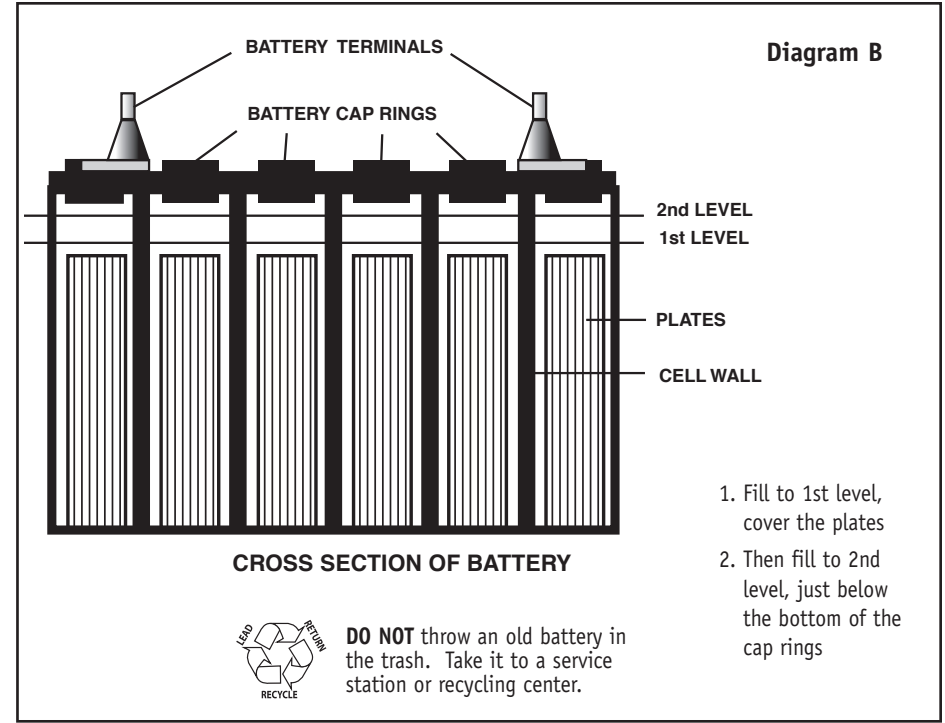
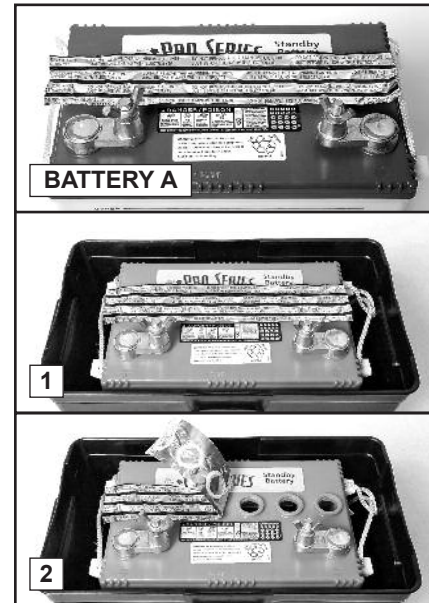

upright above the pack and squeeze the hose forcing all the acid back into the pack.

4. Position the acid pack and battery as shown below. Pinch the end of the hose together and cut off the tip. Insert the end of the hose into each cell. Control the flow by pinching

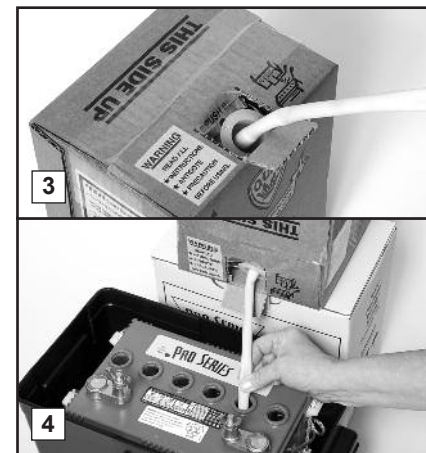

the hose with thumb and forefinger. **Fill each cell of the battery to a level just covering the battery plates, and then go back and top off each cell equally. It is important to have all the cells filled equally or the battery will not operate properly.** The acid should reach a level about 1/4" below the cap ring as shown in the diagram above. DO NOT OVERFILL THE BATTERY. (Diagram B)

A newly filled battery will sometimes require additional acid after about 20 minutes. Re-examine the fill level, and add additional acid if necessary. The battery acid may bubble at this time and give off a sulfur-like smell, but this is normal. After the battery has been filled, screw the caps securely on the top of the battery.

### CAUTION

When you fill the battery for the FIRST time, it will be the ONLY time you add acid to the battery. In the future, when the fluid level is low, add distilled water to the cells. NEVER add more acid.



If your battery looks like the battery above, follow these directions.

1. Place the battery box on the floor. Place the dry (unfilled) battery into the battery box.
2. Remove the two battery caps by lifting them up with a screwdriver. **DO NOT** lift the cap by prying it up from the groove on the back of the cap. It may damage the vent.
3. Carefully push in the perforated tab at the top of the acid pack. Lift up the large tab and pull out the dispensing hose. Hold the hose upright above the pack and squeeze the hose forcing all the acid back into the pack.
4. Position the acid pack and battery as shown at the right. Pinch the end of the hose together and cut off the tip. Insert the end of the hose into each cell. Control the flow by pinching the hose with thumb and forefinger. **Fill each cell of the battery to a**

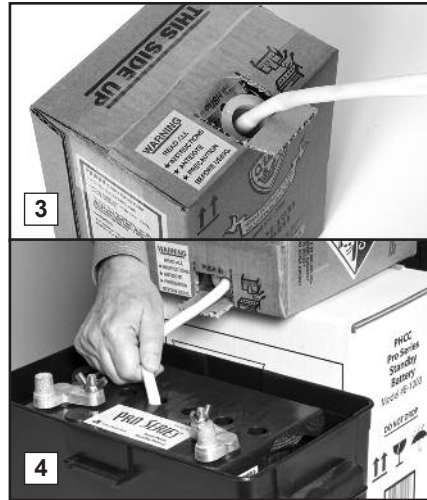

level just covering the battery plates, and then go back and top off each cell equally. It is important to have all the cells filled equally or the battery will not operate properly. The acid should reach a level about 1/4" below the cap ring as shown in Diagram B on the previous page. **DO NOT OVERFILL THE BATTERY.** (See diagram B)

A newly filled battery will sometimes require additional acid after about 20 minutes. Re-examine the fill level, and add additional acid if necessary. The battery acid may bubble at this time and give off a sulfur-like smell, but this is normal. After the battery has been filled, press the caps securely on the top of the battery.

### CAUTION

When you fill the battery for the **FIRST** time, it will be the **ONLY** time you add acid to the battery. In the future, when the fluid level is low, add distilled water to the cells. **NEVER** add more acid.

## System Connections

### ⚠ DANGER

Risk of electrical shock or battery explosion, which can cause serious injury or death. Wear eye protection. Work in a well-ventilated area. Do not smoke or allow a spark or flame in the vicinity of the battery. Avoid dropping metal

tools on the battery. If battery acid contacts eyes, flush with water for 15 minutes. Review the safety instructions on page 1.

When you position the control unit on the discharge pipe, be sure the charger cord will reach the AC power outlet, and the pump cable and the float switch will reach the bottom of the sump. Position the unit in a well-ventilated area. Do not place anything on top of the battery. (Diagram C, page 6)

1. **Mounting the control unit:** (a) Thread one plastic wire tie through the two mounting brackets on the back of the control unit. (b) Secure the controller to the discharge pipe of the Pro Series pumps by wrapping the tie around the pipe and pulling it tight.
2. **Connecting the backup pump:** Remove the security tag from the pump and plug the pump wires into the pump connector on the back of the control unit.
3. **Installing the battery fluid sensor:** Remove the cover of the battery box by pushing in the tabs on the front and back, then lifting up. Fan the area around the top of the battery with a piece of cardboard (or another non-metallic material) to remove any hydrogen or oxygen gas that may have been emitted from the battery.

4. If you are using BATTERY A, replace the battery cap that is 2nd from the POSITIVE (+) post with the battery cap that is provided in the Pro Series package. An arrow on the top of the battery marks this position. There are two holes in the battery cap. Insert the fluid sensor in the hole that is off-center on the top of the cap. Do not glue the sensor into the cap.
5. If you have BATTERY B, a hole has been molded into the top of the battery to accept the fluid sensor rod. The sensor hole is marked by the label on top of the battery. Hold the sensor straight and press it firmly into the hole all the way up to the connector. Do not bend the sensor rod.

### CAUTION

6. If you are not using the PHCC Pro Series Standby battery, you cannot use the battery fluid sensor. However, you must attach the sensor to the POSITIVE (+) post of the battery or the alarm will sound continuously. The PHCC Pro Series sump pump system will not warn you if the fluid level is low in this configuration. You will need to check your battery every couple of months to see if it needs water. If the

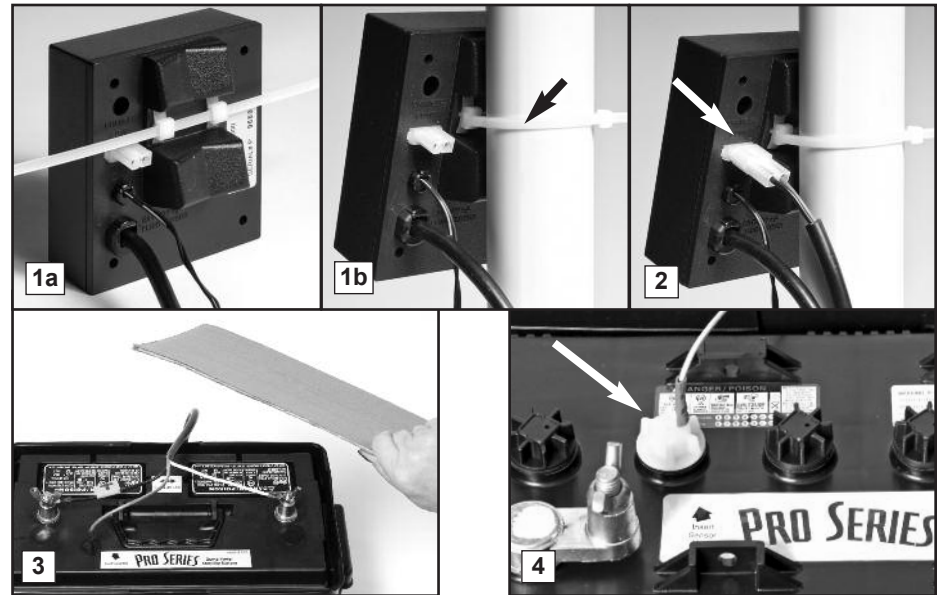

battery dries out, the system will not work. If you are using a maintenance-free battery, you cannot add fluid to the battery. The sensor must be attached to the POSITIVE (+) post of the maintenance-free battery to disconnect the fluid alarm.

7. **Connecting the battery:** Remove the wing nuts from the battery terminals. Remove the security tag from the battery cables. Attach the battery cables to the battery...the WHITE wire to the NEGATIVE (-) post, and the BLACK wire to the POSITIVE (+) post. Replace the wing nuts and tighten them.
8. **Connecting the charger:** Immediately plug the charger into the charger hole on the back of the control unit, then into an AC outlet on the wall. (You should provide additional protection for the control unit by using a surge protector.)
9. If any of the alarms are sounding, press the

RED button on the front of the control panel to silence them.

10. Secure the cover on the battery box by slipping the tabs through the fittings on the front and back of the box.
11. **Connecting the primary pump:** Mount the controller to the wall through the 2 holes on the cabinet using proper mounting hardware for the application. The controller should be mounted at least 4' from the floor and 1' from the outlet. Plug the controller into a properly grounded 3-prong outlet. Then plug the primary pump into the receptacle on the controller. Check to ensure the float switch wire is properly secured to the controller. The float switch wire includes a connector that can be separated from the controller when the wire needs to be threaded through small openings. The float switch connector has a safety locking pin. This pin will

prevent the float switch from accidentally being disconnected from the controller. To remove the pin, push the pointed end of the pin into the float connector and pull it out from the other end. The float switch wire can now be disconnected. Make sure to reinstall the pin after the float switch is reconnected. Using a flathead screwdriver, adjust the dial on the front of the controller to select the number of seconds that the primary pump will run after the float drops. The dial can be adjusted from 5-45 seconds. The manufacturer default is about 10 seconds.

12. For a neater installation, secure the cables from the controllers to the discharge pipe in a couple places with additional cable ties. Make sure the wires are not touching each other or overlapping each other.
13. After the initial installation, be sure to check the pump operation by filling the sump with water and observing the pump through one full cycle. The primary pump should run for 10 seconds after the lower float drops.

14. A pit cover is recommended for all installations as a safety measure, and to prevent debris from falling into the pit. Place the cover on top of the pit making sure not to pinch or crimp the pump wires through the cover. The pit cover usually has an existing hole that will allow the cords to be passed through it, or you can drill a hole in the cover.

## Battery Maintenance

Measuring the battery fluid level is one of the most important features of the system. It is important to check the battery fluid levels at least once every 4-6 months. Detailed instructions on adding distilled water to the battery can be found within the **Understanding the Warnings & Alarms** section of this manual (page 7, ② **The fluid in the battery is low**). If you are not using a PHCC Pro Series standby battery, you cannot use the battery fluid sensor. You will need to attach the fluid sensor to the POSITIVE (+) post of the battery or the alarm will sound continuously. The system will NOT warn you if the fluid level is low in this configuration. You will need to check your battery every couple of months to see if it needs water. If the battery dries out, the system will not work. If you are using a maintenance free battery or sealed AGM battery you will also need to attach the fluid sensor to the POSITIVE (+) post of the battery or the or the alarm will sound continuously.

## Product Operation

The dual float switch on the primary pump contains two large floating rings enclosed within a protective cage. Water will lift the bottom float by  $\frac{1}{4}$ ", which will activate the pump. If for any reason the lower float does not activate the pump, the water will rise to the second float, and it will activate the pump. As the pump evacuates the water from the pit, the floats will drop. The pump will run for an additional 10 seconds to extend the cycle after the lower float drops. The blue controller for the primary pump powers this switch.

During a power outage, or if more water is entering the sump than the primary pump can handle, the backup pump will automatically begin pumping. It also has a dual float switch, so if one float fails to activate the pump, the

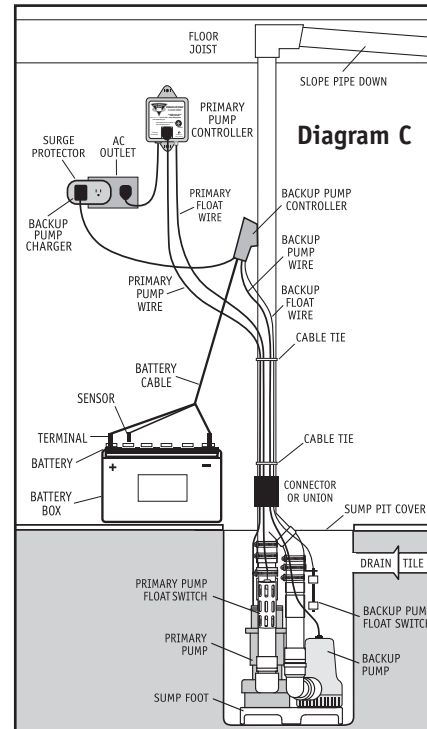
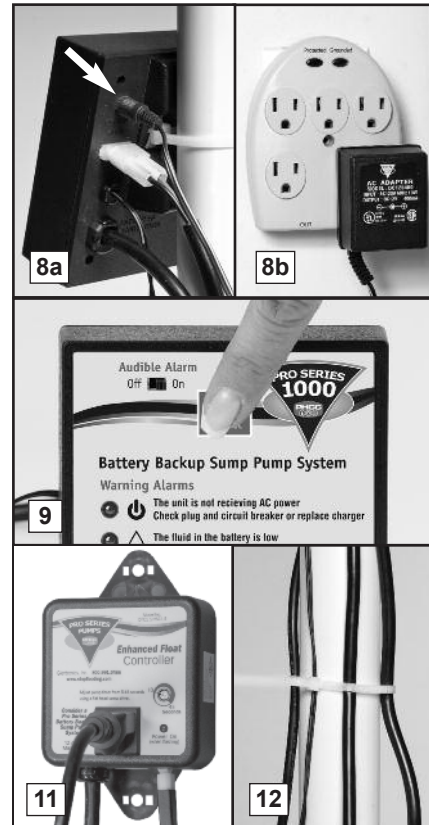
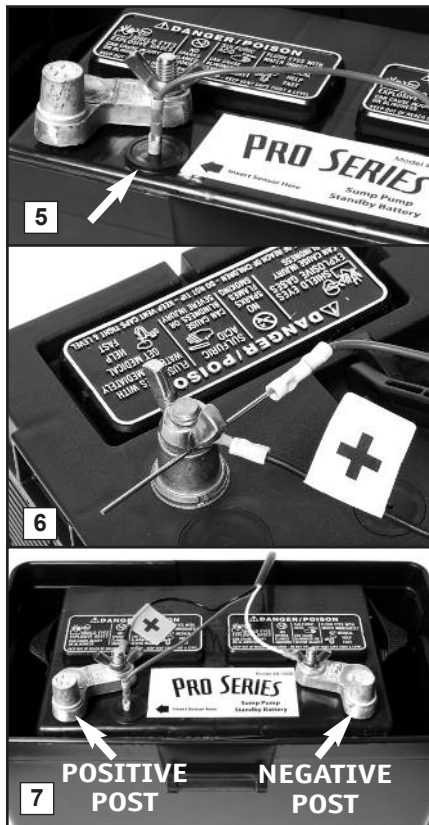

second float will activate the pump as soon as the water reaches that level. As the water recedes below the float switch, a timer in the control unit will run the pump an additional 45 seconds to empty the pit.

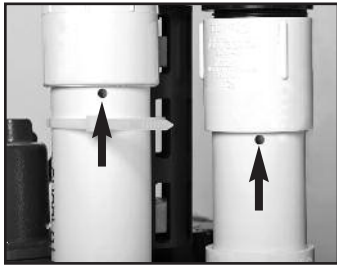

While the pumps are active, water will come out of the 1/8" hole that is drilled in the pipe above the pump. This is normal. The hole is needed to prevent an air lock within the system. Do not obstruct this hole or an air lock may prevent the pump from activating, and the basement will flood.

Batteries and sump pumps need maintenance. The control unit on the backup system monitors the battery and power conditions, and sounds an alarm when maintenance is required. Following is an explanation of the warnings and alarms.

## Understanding the Warnings & Alarms

The Pro Series backup pump control unit features a series of warning lights that pinpoint potential

Warning	Alarm can be silenced before problem is corrected	Alarm shuts off automatically when problem is corrected
Power problem	Yes	Yes
Fluid level is low	No	Yes
Pump was activated	Yes	No, push the RED button
System is operating	No alarm	No alarm
Battery problem	No	Yes

problems. In addition, an alarm sounds to alert you to the problem. In some cases the lights and alarm will go off automatically when the problem has been solved. In others, the RED button on the front of the control unit must be pushed to silence the alarm. Refer to the table below for a quick review of the features and their corresponding alarm status.

### SILENCING THE ALARM DURING AN EMERGENCY

The Pro Series backup pump control unit is equipped with a switch that will silence the audible alarm during an extended emergency. The "AC power" ① and "Pump" ③ alarms can be silenced during a power outage or during heavy rains when the pump is activated repeatedly.

To silence both the "AC power" and "Pump" alarms, slide the "Audible Alarm" switch to OFF. The "AC power" and/or the "Pump" light will remain on, but the audible alarm will not sound. When the emergency has ended, slide the switch to the ON position to resume the full monitoring capability, or you will not be warned the next time an emergency occurs.

The "Fluid level" ②, and "Battery problem" ⑤ alarms cannot be silenced. Both require immediate attention.

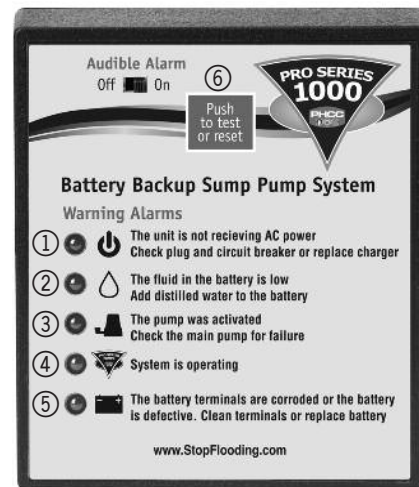

#### ① The unit is not receiving AC power

There are several causes for power failure. The

most common is a power outage by your electric company. During this emergency, the Pro Series system will automatically switch to battery power and protect your basement from flooding. You can silence the "AC power" alarm by sliding the "Audible Alarm" switch to OFF. The alarm will be silenced, but the light will stay on. The system will continue to operate while the power alarm is silenced. **Be sure to slide the switch to the ON position when the power is restored to resume full monitoring capability.**

1. If the power is on in the rest of the house, check the home circuit breaker or fuse box for failure, and correct the problem.
2. Check the charger. Make sure it is securely plugged into the wall outlet. Make sure the outlet is working.
3. Check the charger plug that fits into the rear panel of the control unit. Make sure it is securely plugged into the control unit.

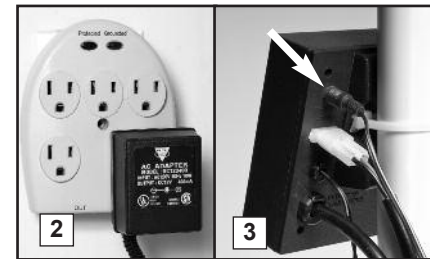

The control unit must receive 115 volts AC +/- 5% from the AC outlet. Any voltage lower than 110 volts will activate the "AC power" alarm. Lower voltages can be caused by utility company brown outs or a heavy power draw from other appliances on the same circuit. Reduce the number of appliances on the circuit.

If all the connections are secure and the wall outlet is operating, but the "AC power" warning light is still on, replace the charger unit with the Pro Series part number 1015003. Contact Glentronics at 800-991-0466 for parts.

#### ② The fluid in the battery is low



Risk of electrical shock or battery explosion, which can cause serious injury or death. Wear

eye protection. Work in a well-ventilated area. Do not smoke or allow a spark or flame in the vicinity of the battery. Avoid dropping metal tools on the battery. If battery acid contacts eyes, flush with water for 15 minutes and get prompt medical attention. Review the safety instructions on page 1.

### REFER TO THE PHOTOS BELOW

If this warning light and alarm are on, you need to add distilled water to the battery. This alarm cannot be silenced. When the battery is refilled and the sensor is replaced, the alarm will go off automatically. Battery fluid levels should be checked every 4-6 months.

### REFILLING THE BATTERY

1. Unplug the primary pump, and its blue piggyback controller from the wall outlet. Unplug the charger for the backup pump control unit, too.
2. Remove the cover of the battery box by pushing in the tabs on the front and back, then lifting up.
3. Fan the area around the top of the battery with a piece of cardboard (or another non-metallic material) to remove any hydrogen or oxygen gas that may

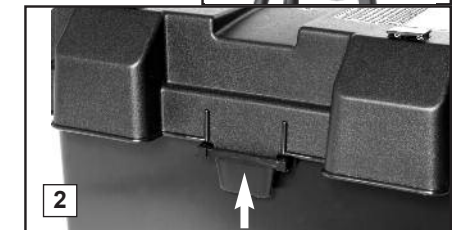



have been emitted from the battery.

- Remove the fluid sensor from the top of the battery, and then unscrew the wing nuts and remove the battery cables from the battery.
- Pry up the two battery caps, or unscrew the six battery caps depending on the configuration of your battery. Add distilled water to the battery filler bottle and replace the nozzle. Place the nozzle of the battery

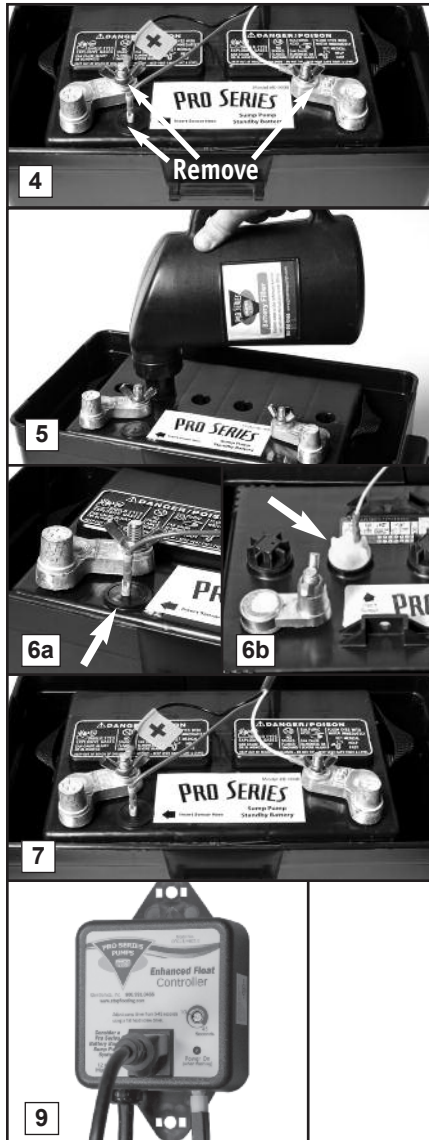

filler into each cell of the battery and press down. It will fill the battery cell to the correct level and stop automatically. If distilled water is not available, tap water with a low mineral content may be used. Well water is not recommended. **NEVER ADD MORE ACID.**

- Replace the battery caps. Replace the fluid sensor in the hole on the top of the battery, or in the cap 2nd from the POSITIVE (+) post, depending on the configuration of your battery.
- Replace the battery cables...the WHITE wire to the NEGATIVE (-) post, and the BLACK wire to the POSITIVE (+) post. Replace the wing nuts and tighten.
- Replace the cover on the battery box.
- Plug the primary pump into the blue piggyback controller, and plug both into the wall outlet.

### ③ The pump was activated

When the water rises in the sump pit and activates the float switch, the pump will begin pumping, and the "Pump was activated" light and alarm will turn on. The alarm stays on to alert you to the fact that the standby system was used to empty water from the sump. Try to determine what caused the system to activate.

- Check the main AC pump for failure. It may not be working, the float switch may be stuck, the float switch wire may not be connected to the main AC controller, or the pump may be too small to handle the inflow of water.
- Make sure the discharge pipe is not clogged or frozen.
- If the power was out, the backup pump was automatically activated. You need to push the RED button on the front of the control panel to reset the alarm.

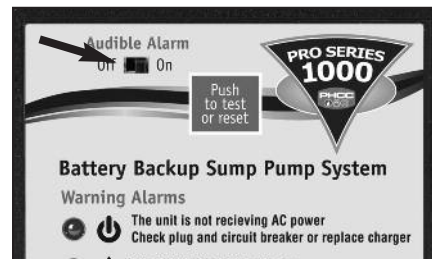

During a power outage or times when the pump is activated repeatedly, you can temporarily silence the alarm by sliding the "Audible Alarm" switch to OFF. **When the primary pump has resumed normal operation, and the backup pump is no longer activating repeatedly, slide the switch to the ON position to resume the full monitoring capability.** The alarm and pump light will still be on. Push the RED button on the front of the control panel to silence the alarm.

### REPLACING THE BACKUP PUMP

Before you begin this process, you will need a new backup pump. You may also want to change the check valves at this time. The check valves have a 1½" MPT on one end, and a 1½" SLIP on the other end. See page 15 for part numbers. You will also need two (2) new wire ties.



### ⚠ DANGER

Risk of electrical shock or battery explosion, which can cause serious injury or death. Wear eye protection. Work in a well-ventilated area. Do not smoke or allow a spark or flame in the vicinity of the battery. Avoid dropping metal tools on the battery. Review the safety instructions on page 1.

**YOU WILL BE DISCONNECTING ALL THE WIRES. BE SURE THEY DO NOT FALL INTO THE SUMP PIT.**

- Unplug the primary pump, and its blue piggyback controller from the wall outlet. Unplug the charger for the backup pump control unit, too.
- Unplug the backup pump from the back of the black control unit.
- Remove the cover of the battery box and fan the area around the top of the battery with a piece of cardboard (or another non-metallic material) to remove any hydrogen or oxygen gas that may have been emitted from the battery.
- Remove the sensor from the battery, and remove the battery wires from the battery terminals. Be sure they do not touch each other while one is connected to the battery.

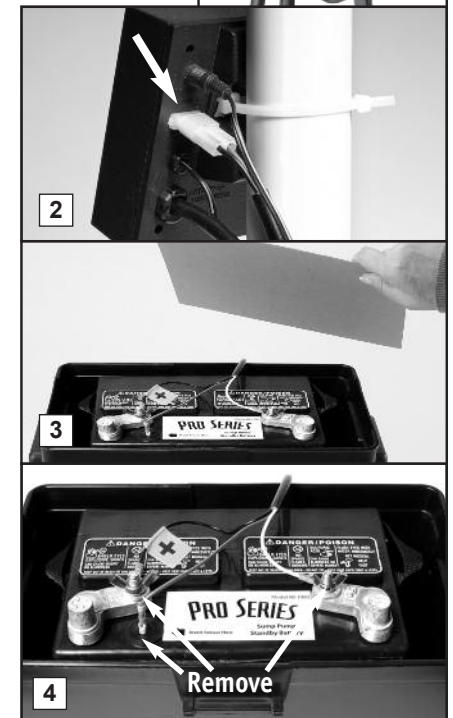

5. Slowly loosen the no hub coupling on the top of the combination pump assembly to separate the pipes. The water trapped in the pipe will pour out into the sump as the no hub coupling is loosened.
6. Separate the pump assembly from the no hub coupling and lift it out of the sump pit by the handle on the primary pump. Tip the assembly over the sump pit to drain away any remaining water.
7. Lay the pumps down and remove the two (2) screws holding the backup pump to the sump foot.



8. (a) Squeeze the clamps on the elbow of the backup pump with a wrench to loosen them. (b) Then squeeze the clamps together with your fingers and pull the pump off of the elbow.
9. Remove the elbow from the new pump. You will not need it. Squeeze the clamps on the pump elbow and insert the elbow into the new pump.
10. Screw the base of the new backup pump into the sump foot.
11. (OPTIONAL) While you have the pump out of the sump pit, this would be a good time to replace the check valves. A check valve with 1½" MPT on one end, and 1½" SLIP on the other is commonly available, or you may order this part #1141001 from Glentronics. (a) You will need to loosen the screws on the no hub couplings on both pipes. (b) Remove the float switches. Then ease off the Y-assembly. (c) The check valves can then be

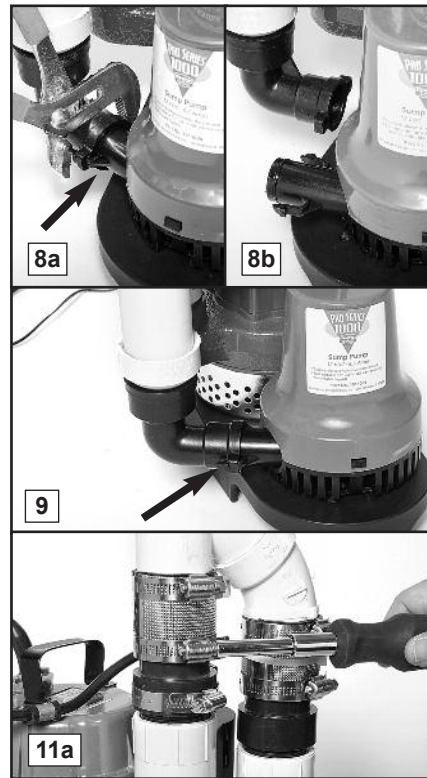

- unscrewed from the pipes and new valves can be screwed into the pipes. (d) Replace the Y-assembly and tighten the screws on the no hub couplings. (e) Replace the float switches making sure they are vertical with the float for the primary pump lower than the float for the backup pump. You will need to secure them with a wire tie.
12. Lower the pumps into the sump pit by the handle on the primary pump.
13. Ease the Y-assembly back into the no hub coupling on the discharge pipe and tighten the hose clamps.
14. Connect the backup pump to the back of the black control unit.
15. Insert the fluid sensor into the top of the battery, or into the battery cap, depending on which battery you own.

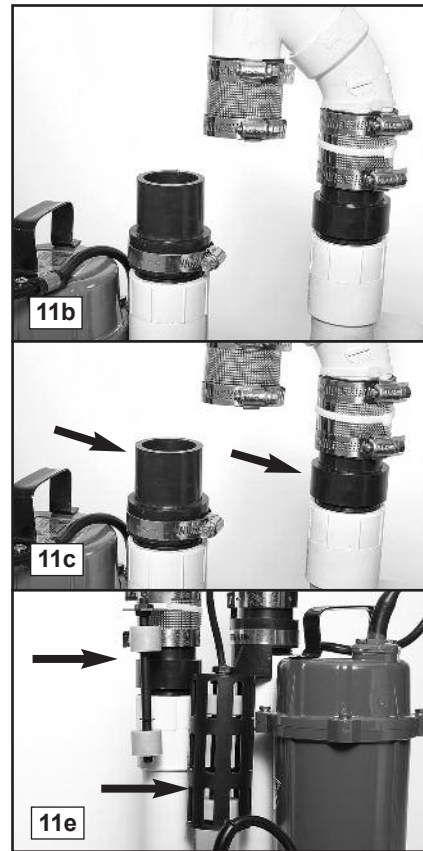

16. Connect the battery wires to the battery terminals, WHITE to the NEGATIVE (-) post, and BLACK to the POSITIVE (+) post. Replace the cover on the battery box.
17. Plug the charger from the black control unit into the outlet. (You should provide added protection for the control unit by using a surge protector.)
18. Plug the primary pump into the blue piggyback controller and then plug the controller into the wall outlet. Check to ensure the float switch wire is properly secured to the controller.
19. If any of the alarms are sounding, press the RED button for 1 second.
20. Fill the sump with water to make sure the primary pump is working. When the pumping cycle is finished, lift the float switch on the backup pump to make sure it activates the backup pump.

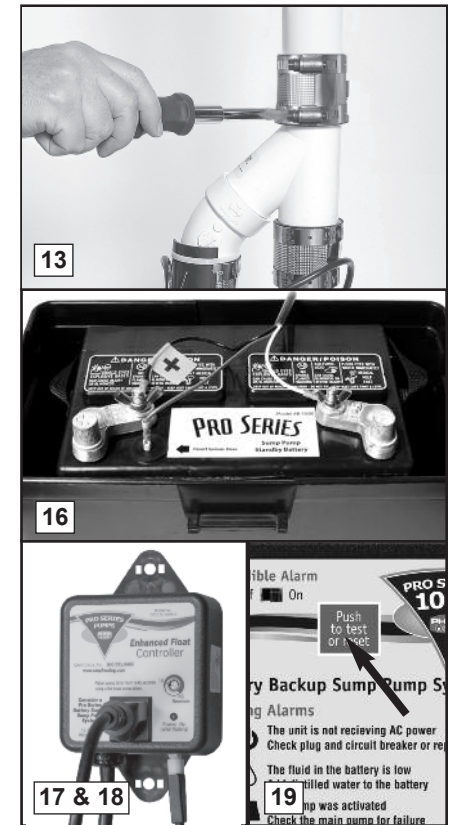

## REPLACING THE PRIMARY PUMP

Before you begin this process, you will need a new primary pump. You may also want to change the check valves at this time. The check valves have a 1½" MPT on one end, and a 1½" SLIP on the other end. See page 15 for part numbers. You will also need two (2) new wire ties.



### **⚠ DANGER**

Risk of electrical shock or battery explosion, which can cause serious injury or death. Wear eye protection. Work in a well-ventilated area. Do not smoke or allow a spark or flame in the vicinity of the battery. Avoid dropping metal tools on the battery. Review the safety instructions on page 1.

**YOU WILL BE DISCONNECTING ALL THE WIRES. BE SURE THEY DO NOT FALL INTO THE SUMP PIT.**

1. Unplug the primary pump, and its blue piggyback controller from the wall outlet. Unplug the charger for the backup pump control unit, too.
2. Unplug the backup pump from the back of the black control unit.
3. Remove the cover of the battery box and fan the area around the top of the battery with a piece of



cardboard (or another non-metallic material) to remove any hydrogen or oxygen gas that may have been emitted from the battery.

4. Remove the sensor from the battery; remove the battery wires from the battery terminals. Be sure they do not touch each other while one is connected to the battery.
5. Slowly loosen the no hub coupling on the top of the combination pump assembly to separate the pipes. The water trapped in the pipe will pour out into the sump as the no hub coupling is loosened.
6. Lift the pump assembly out of the pit by the handle on the primary pump. Tip the assembly over the sump pit to drain any

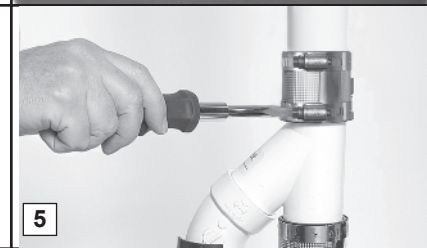
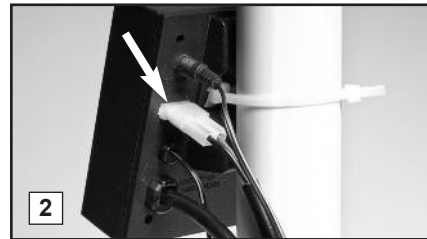

- remaining water.
7. Unscrew the no hub coupling on the pipe connected to the primary pump.
8. Lay the pumps down and remove the three (3) screws holding the primary pump to the sump foot. Save these screws or replace them with #14 x ¾" self-tapping stainless steel screws.
9. Ease the pump out of the no hub coupling.
10. Loosen the hose clamp holding the float switch, cut the wire tie holding the switch, and remove the switch from the pipe. Note its position.
11. Unscrew the pipe and the adapter from the

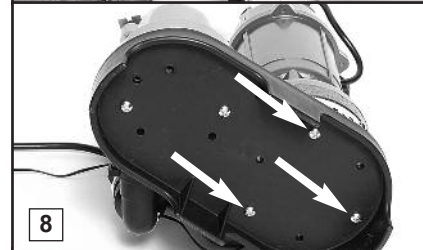

- primary pump, and screw it on to the new pump.
12. (OPTIONAL) While you have the pump apart, this would be a good time to replace the check valves. A check valve with 1½" MPT on one end, and 1½" SLIP on the other is commonly available, or you may order this part #1141001 from Glentronics. (a) Unscrew the check valve on the primary pump and screw in a new one. (b) To replace the other check valve, remove the other no hub coupling and the float switch and ease the Y-assembly off of the pipe. Unscrew the old check valve and screw in the new valve.



13. Reconnect the pipes to the Y-assembly and line up the pipe on the primary pump parallel to the pipe on the backup pump. Tighten the no hub couplings.
14. The strainers on the pumps may vary slightly. If the new strainer does not line up with the holes on the sump foot, drill three holes through the foot into the strainer in the same positions where the screws were before. Use a #4 or a 3/16" drill bit. Screw the sump foot on to the pump with #14 x 3/4" self tapping stainless steel screws.

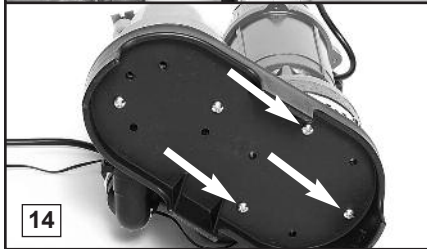

15. Replace the float switches making sure they are vertical with the float for the primary pump lower than the float for the backup pump. You will need to secure them with a wire tie.
16. Lower the pump back into the pit by the handle of the primary pump.
17. Connect the top of the system to the no hub coupling and tighten the hose clamp.
18. Connect the backup pump to the back of the black control unit.
19. Insert the fluid sensor into the top of the battery, or into the battery cap, depending on which battery you own.
20. Connect the battery wires to the battery terminals, WHITE to the NEGATIVE (-) post, and BLACK to the POSITIVE (+) post. Replace the cover on the battery box.

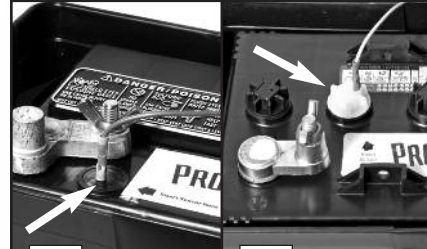
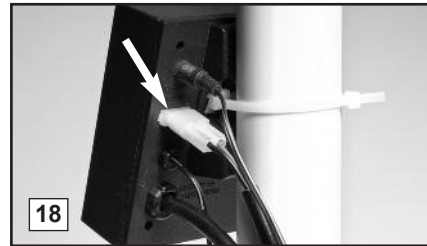

21. Plug the charger from the black control unit into the outlet. (You should provide added protection for the control unit by using a surge protector.)
22. Plug the primary pump into the blue piggyback controller and then plug the controller into the wall outlet. Check to ensure the float switch wire is properly secured to the controller.
23. If any of the alarms are sounding, press the RED button for 1 second.
24. Fill the sump with water to make sure the primary pump is working. When the pumping cycle is finished, lift the float switch on the backup pump to make sure it activates the backup pump.

#### ④ The system is operating

This green light should always be flashing. It will flash when there is power coming from either the battery or the AC outlet.

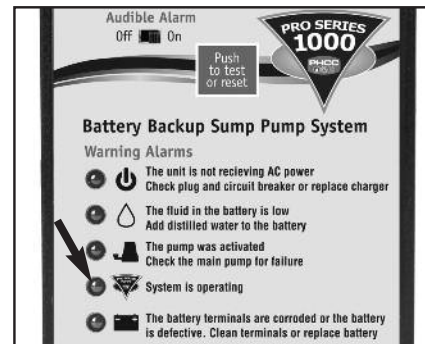

#### ⑤ The battery terminals are corroded or the battery is defective

This light and alarm will come on when the control unit detects there is less than 1/2 hour of pumping power left in the battery, or that the battery is defective. The alarm cannot be silenced, because action needs to be taken to protect your basement. If your battery is more than five (5) years old, replace it. If not, here are several situations that would cause the pump to run the battery for an extended time and

discharge the battery: Check the list below before you replace the battery.

- If the top light on the controller is also on, it means that the unit is not receiving AC power. Either the AC power is out, the circuit breaker has blown, or the outlet is bad. When the problem is corrected, the battery should recharge.
- If the third light on the controller is also on, check your main pump for failure. The backup pump may have been activated repeatedly if your main AC pump is broken or you are experiencing heavy rains and your main pump cannot keep up with the inflow of water. You may need to upgrade or replace your main pump. When the problem is corrected, the battery should recharge.
- If no other lights are on, this means the terminals may be corroded, and the battery cannot charge properly. Unplug the charger from the wall outlet. Then, check the battery cables and the battery terminals for corrosion. Clean and tighten them as needed. The procedure is described on page 12.

If the battery terminals have been cleaned and the light is still on, there could be a problem with the controller or the battery. The best way to determine if the battery is the problem is to have it charged and load tested at any local car service station. If the battery is bad and less than one (1) year old, it can be returned to the place of purchase for a replacement (receipt required). If the battery is good, contact Glentronics' service department for further instructions. The phone number is 800-991-0466.

If the battery alarm goes on while the pump is running and the power is out, you will have a minimum of one-half (1/2) hour of continuous pumping time to replace the battery. (In most cases, the pump does not run continuously, and therefore, you actually have a longer time to replace it.) You will not be able to silence the alarm. Left unattended, the basement will flood. In a severe emergency, if a replacement battery is not available, you could temporarily use your car battery, or recharge this battery by connecting it to your car battery. Once the AC

power is restored, the battery will recharge automatically, unless it is old or damaged. The alarm will turn off when the AC power is restored and the pumping energy reaches one-half (1/2) hour or more.

In the event that your Pro Series sump pump system has pumped for an extended period of time, the battery may be very depleted. In this condition, when the AC power is returned to the unit, a battery alarm will continue to sound. The battery may need a longer period to recharge.

For a faster recharge, an automotive or marine battery charger can be used to recharge the battery. Follow the manufacturer's instructions and safety information included with the charger.

**⚠ WARNING**

When another charger is used, first disconnect the Pro Series charger from the control unit, and then disconnect the control unit from the battery. *Using another charger without disconnecting the control unit will destroy the control unit and void the warranty.*

**TO CLEAN THE BATTERY TERMINALS AND CABLES**

**⚠ DANGER**

Risk of electrical shock or battery explosion, which can cause serious injury or death. Wear eye protection. Work in a well-ventilated area. Do not smoke or allow a spark or flame in the vicinity of the battery. Avoid dropping metal tools on the battery. If battery acid contacts eyes, flush with water for 15 minutes and get prompt medical attention. Review the safety instructions on page 1.

**REFER TO THE PHOTOS AT RIGHT**

1. Unplug the primary pump, and its blue piggyback controller from the wall outlet. Unplug the charger for the backup pump control unit, too.
2. Remove the cover of the battery box by

pushing in the tabs on the front and back, then lifting up.

3. Fan the area around the top of the battery with a piece of cardboard (or another non-metallic material) to remove any hydrogen or oxygen gas that may have been emitted from the battery.
4. Remove the fluid sensor from the top of the battery. Unscrew the wing nuts. Remove the battery cables.
5. Clean the battery posts with a battery terminal cleaner or a wire brush.

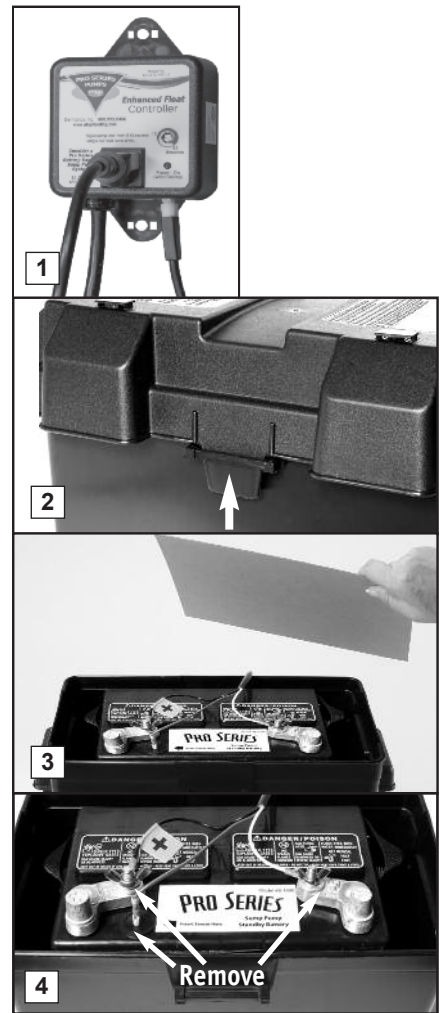

6. Clean any corrosion off of the ring connectors on the ends of the battery wires. Use a stiff brush or sandpaper. **DO NOT** apply corrosion resisting sprays or pads to the terminal rings or posts after you have cleaned them, since this could prevent the system from charging properly.
7. Replace the fluid sensor in the top of the battery. Then replace the battery cables, WHITE to the NEGATIVE (-) post and BLACK to the POSITIVE (+) post. Tighten the wing



8. Plug the primary pump into the blue piggyback controller and then plug the controller into the wall outlet. Check to ensure the float switch wire is properly secured to the controller.
9. If any of the alarms are sounding, press the RED button on the front of the control panel for one (1) second.

**REPLACING THE BATTERY**

**⚠ DANGER**

Risk of electrical shock or battery explosion, which can cause serious injury or death. Wear eye protection. Work in a well-ventilated area. Do not smoke or allow a spark or flame in the vicinity of the battery. Avoid dropping metal tools on the battery. If battery acid contacts eyes, flush with water for 15 minutes and get prompt medical attention. Review the safety instructions on page 1.

**REFER TO THE PHOTOS BELOW AND ON PAGE 13**

1. Unplug the primary pump, and its blue piggyback controller from the wall outlet. Unplug the charger for the backup pump control unit, too.

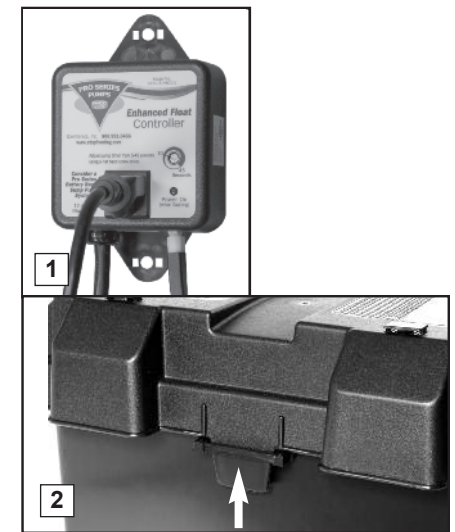

- Remove the cover of the battery box by pushing in the tabs on the front and back, then lifting up.
- Fan the area around the top of the battery with a piece of cardboard (or another non-metallic material) to remove any hydrogen or oxygen gas that may have been emitted from the battery.
- Remove the fluid sensor from the top of the battery. Unscrew the wing nuts and remove the battery cables.
- Remove the old battery from the battery box and place the new battery in the box. Fill the



battery following the instructions on page 4 or 5.

- Clean any corrosion off of the ring connectors on the ends of the battery wires. Use a stiff brush or sandpaper. **DO NOT** apply corrosion resisting sprays or pads to the terminal rings or posts after you have cleaned them, since this could prevent the battery from charging properly.
- Replace the battery cables, WHITE to the NEGATIVE (-) post and BLACK to the POSITIVE (+) post. Tighten the wing nuts.
- Insert the fluid sensor in the top of the battery, or in the cap 2nd from the POSITIVE (+) post, depending on the configuration of your battery. Replace the cover on the battery box.

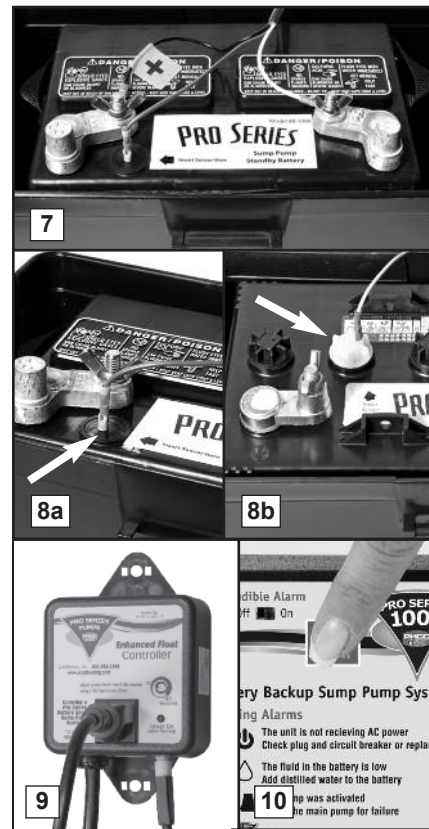

- Plug the primary pump into the blue piggyback controller and then plug the controller into the wall outlet. Check to ensure the float switch wire is properly secured to the controller.
- If any of the alarms are sounding, press the RED button on the front of the control panel for one (1) second.

### ⑥ Test/reset button

The TEST button may be used to check the backup pump and system. Push the TEST button. This will activate the pump for as long as you hold the button. It will stop as soon as you let go of the button.

While the pump is active, water will come out of the 1/8" hole that was drilled into the PVC discharge pipe. This is normal. This hole is needed to prevent an air lock within the system. **DO NOT** obstruct the hole or an air lock may prevent the system from activating.

If the "Pump was activated" alarm is sounding, press the button for one (1) second to reset the alarm.

### TESTING THE FLOAT SWITCH FOR THE BACKUP PUMP

*It is important to manually test the float switches periodically.*

#### **⚠ DANGER**

**Unplug the main AC pump when installing or servicing the backup pump to avoid electric shock. Failure to do so could cause serious injury or death. Review the safety instructions on page 1.**

Lift the float up and let go. This will activate the pump. The control unit will run the pump for approximately 45 seconds so it can empty all the water in the sump pit. If there is no water in

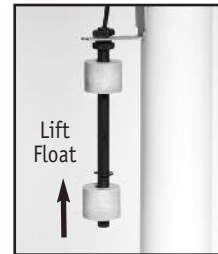

the pit, the pump can run dry for this amount of time. The alarm will sound and the "Pump was activated" light will go on. After the pump has stopped, push the RED button to silence the alarm. If the RED button is pressed before the pump has stopped, the alarm will go off temporarily. Wait for the pump to stop pumping, and then push the RED button on the front of the control unit to completely silence the alarm.

While the pumps are active, water will come out of the 1/8" hole that is drilled in the pipe above the pump. This is normal. The hole is needed to prevent an air lock within the system. **DO NOT** obstruct this hole or an air lock may prevent the pump from activating, and the basement will flood.

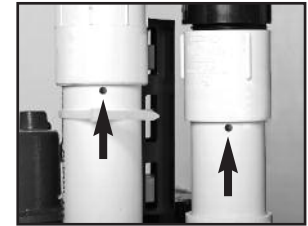

**BE SURE TO PLUG IN THE MAIN AC PUMP WHEN YOU HAVE COMPLETED THE TEST.**

### TESTING THE FLOAT SWITCH FOR THE PRIMARY PUMP

Lift the float up with a pencil, or another non-metallic item, and let it go to activate the pump. The pump will run an additional 10 seconds after the float returns to the original position. It will not damage the pump to run it for this short time if the sump pit is dry. However, do not hold the float up for an extended time without water in the sump pit.

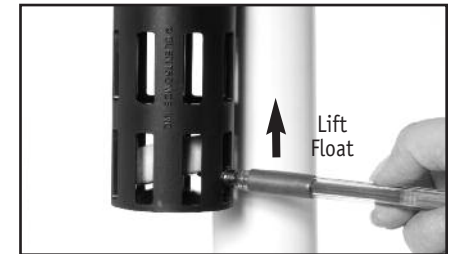

While the pumps are active, water will come out of the 1/8" hole that is drilled in the pipe above the pump. This is normal. The hole is needed to prevent an air lock within the system. **DO NOT** obstruct this hole or an air lock may prevent the pump from activating, and the basement will flood.



## PARTS & SERVICE INFORMATION

You can receive technical support, parts, or service information by calling Glentronics, Inc. at **800-991-0466**, or by visiting the Pro Series website at **www.stopflooding.com**. Send your unit to the following address if repairs are needed:

Glentronics, Inc.  
645 Heathrow Drive  
Lincolnshire, IL 60069-4205

## MAINTENANCE CHECK LIST

Maintenance should be performed 1-2 times per year

1. Lift the float switch on both pumps as described at above.
2. Remove all debris from the bottom of the pit and pump strainer.
3. Remove all debris from the water.
4. Remove all debris from the float switches.
5. Fill the pit with water. Make sure the pumps turn on at the intended level.
6. While the pumps are running, make sure they are evacuating water at a good pace and water is coming out of the 1/8" air bleed hole.
7. Remove the fluid sensor and yellow cap from the battery and rinse any residue buildup from the bottom of the battery cap. Replace the cap and fluid sensor.
8. Check battery fluid levels once every four to six months.
9. Check and clean battery terminals.

# Replacement Parts List

## PS -C11 Description

- Controller for backup pump
- Dual float switch with controller for AC pump
- 1/3 HP AC sump pump
- PHCC 1000 backup pump
- Battery box
- PVC "Y" fitting
- Battery cap with hole
- Sump foot
- Stainless steel screw, #14 x 3/4" \*
- 45° PVC pipe fitting, 1-1/2" \*
- Pipe adapter for backup pump, 1-1/2" FTP x 1-1/2" slip \*
- Wire tie for float switch, 11" \*
- Stainless steel hose clamp, 2-1/2" diameter \*
- Check valve, 1-1/2" MPT x 1-1/2" SLIP \*
- No-hub coupling, 1-1/2" \*

\*Stock items available in plumbing department

Call 800-991-0466 to order parts.

Part No.
PHCC-1000-CON1
DFC1
ST1033-GL
1011009
1113003
1120007
1125000
1143000
1100024
1200008
1120009
1122000
1122002
1141001
1142000

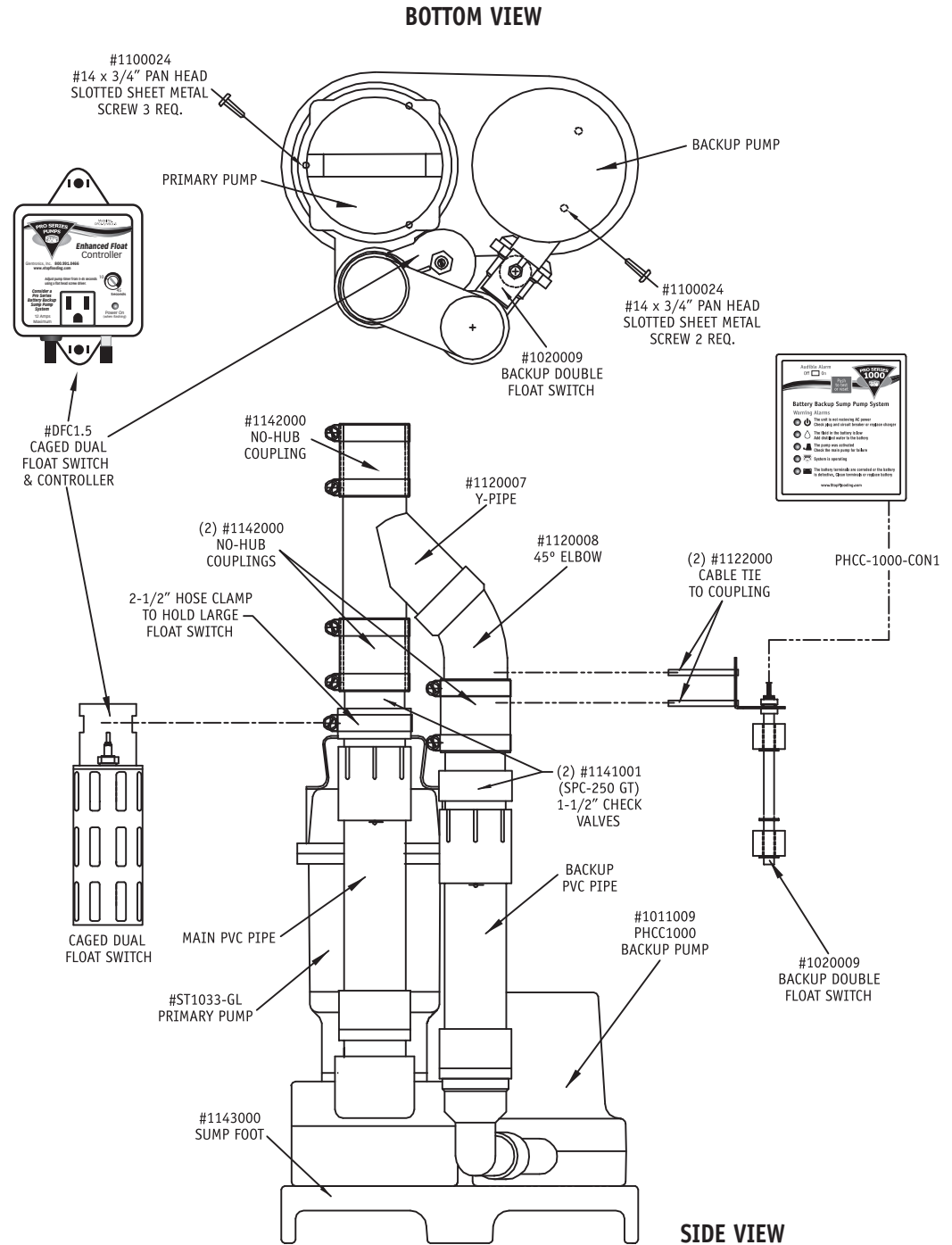



## Primary Pump Troubleshooting Guide

### **⚠ DANGER**

Read safety warnings & instructions before attempting any repairs or maintenance.

Potential Cause	THE PUMP WILL NOT START OR RUN	Solutions
Pump is not plugged in	Plug pump in properly (see instructions)	
No AC power	Check circuit breaker or fuse, and GFI reset button	
Poor power source	Check circuit line wires, cable and outlet	
Locked impeller	Remove strainer and clear obstruction	
Defective float switch	Replace float switch with new float switch	
Defective pump	Replace pump with new pump	

Potential Cause	THERMAL PROTECTOR TRIPPING OR NOT FUNCTIONING	Solutions
Locked impeller	Remove strainer and clear obstruction	
Incorrect power supply	Check power supply source and voltage	
Pump running continuously with no water present	Check float switch	

Potential Cause	PUMP STARTS AND STOPS TOO FREQUENTLY	Solutions
Float switches mounted too low	Raise both float switches	
Water back flowing from pipe	Install or replace check valve	
Malfunctioning float switch	Replace float switch with new float switch	

Potential Cause	PUMP WILL NOT SHUT OFF	Solutions
Clogged or frozen discharge	Clear blockage or thaw frozen line	
Blocked intake strainer	Clear debris from intake strainer	
One or both of the floats is obstructed and cannot drop down	Clear debris from inside the float cage (Loosen nut on top of float, then remove c-clip on bottom of float. Remove debris. Tighten nut on top of float, then replace c-clip on bottom of float.) When reassembling the float, the magnetic strip on the inside of the float should be facing down.	
Defective float switch	Replace float switch with new float switch	
Check valve is stuck	Replace check valve.	

Potential Cause	INSUFFICIENT OR NO WATER VOLUME	Solutions
Check valve on secondary pump will not close and water re-circulates within the system	Replace the check valve on the secondary pump	
Partially blocked impeller	Remove strainer and clear obstruction	
Clogged or frozen discharge pipe	Clear blockage or thaw frozen line	
Broken or leaking pipe	Repair pipe	
Low power voltage	Check power voltage, wires and cable condition	
Check valve is stuck	Replace check valve.	

Potential Cause	ABNORMAL SOUND OR VIBRATION	Solutions
Check valve is broken	Replace the check valve	
Blocked intake screen	Clear debris from intake screen	
Defective pump	Replace pump	

## Backup Pump Troubleshooting Guide

### **⚠ DANGER**

Read safety warnings & instructions before attempting any repairs or maintenance.

Potential Cause	BATTERY FLUID LOW	Solutions
The battery fluid is low	Add distilled water to each cell of the battery	
The fluid sensor is installed improperly	The fluid sensor should be inserted into the designated hole on the top of the battery and pushed down	
Not using a Pro Series battery	This feature cannot be used. Attach the fluid sensor to the positive post of the battery	

Potential Cause	BATTERY PROBLEM	Solutions
Terminals are corroded	Clean terminals and cables	
Cables are loose	Tighten wing nuts	
Battery is discharged below 25%	Replace battery if power is out. There is only 1 hour of continuous pumping power left. Battery will recharge when power is restored	
Battery is old or damaged	Replace battery	

Potential Cause	POWER FAILURE	Solutions
Power outage	None. The backup pump will run off of the battery. Flip the alarm switch to the off position to silence the alarm. Be sure to flip it back to on when the power is restored.	
An outlet, fuse, or circuit breaker has failed	Try another outlet, replace the fuse, or reset the circuit breaker	
The charger is unplugged from the wall or the back of the controller	Make sure the power cord is plugged in securely	
The control unit is receiving less than 110 volts from the outlet	None, if the utility company has instigated brown outs. Otherwise, reduce the number of other appliances on the circuit	

Potential Cause	PUMP WILL NOT SHUT OFF	Solutions
Backup pump is unplugged	Make sure the pump is securely plugged into the back of the control unit	
Backup pump is clogged	Remove strainer from pump and clean out any debris	
Backup pump is broken	Replace the pump	

Potential Cause	INSUFFICIENT OR NO WATER VOLUME	Solutions
The main AC pump failed because of a power outage	None. The backup pump was activated when needed	
The water was coming into the sump faster than the main pump could evacuate it	None. The backup pump was activated when needed	
The float switch on the main AC pump is stuck or defective	Free the float switch on the main pump or replace it	
The main AC pump is broken	Replace the main AC pump	
The main AC pump could not keep up with the inflow of water	None. The backup pump was activated as needed. If this is a recurring problem, install a higher capacity main pump	
The check valve is stuck and the water cannot pass through it	Replace the check valve	
The discharge pipe is clogged or frozen and the water cannot pass through it	Thaw, clean out the blockage, or replace the discharge pipe	
There is a slight chance of false activation if the float switch cord is wrapped around the AC power cord	Move the float switch cord away from the AC power cord	

Potential Cause	ABNORMAL SOUND OR VIBRATION	Solutions
Check valve is broken	Make sure check valve is functioning, or replace it	
Discharge pipe is clogged or frozen	Clear the discharge pipe	

## Limited Warranty

By opening this package and using this GLETRONICS, INC. product, you are agreeing to be bound by the terms of the GLETRONICS, INC. limited warranty (“warranty”) as set out below. Do not use your product until you have read the terms of the warranty. If you do not agree to the terms of the warranty, do not use the product and return it within the return period stated on your purchase receipt from the retail store or authorized distributor where you purchased it for a refund.

To the extent permitted by law, this warranty and the remedies set forth are exclusive and in lieu of all other warranties, remedies and conditions, whether oral, written, statutory, express or implied. GLETRONICS, INC. disclaims all statutory and implied warranties, including without limitation, warranties of merchantability and fitness for a particular purpose and warranties against hidden or latent defects, to the extent permitted by law. GLETRONICS, INC. will not be liable for any incidental, special or consequential damages for breach of any express or implied warranties on this product. In so far as such warranties cannot be disclaimed, GLETRONICS, INC. limits the duration and remedies of such warranties to the duration of this express warranty and, AT GLETRONICS, INC.'s option, the repair or replacement services described below. Some states (countries and provinces) do not allow limitations on how long an implied warranty (or condition) may last, so the limitation described above may not apply to you.

Any and all causes of action arising from, filed as a result of or in reference to, this warranty or the products described under this warranty shall be governed by and construed under the laws of the State of Illinois. Any cause of action arising from, filed as a result of or in reference to, this warranty or the products described under this warranty shall be filed only in the Circuit Court of the 18th Judicial District, Lake County, Waukegan, Illinois, or in the Northern District of Illinois if filed in Federal Court. The maximum liability for any product described in this warranty shall be the cost of product replacement only.

If any term is held to be illegal or unenforceable, the legality or enforceability of the remaining terms shall not be affected or impaired.

### What is Covered by this Warranty?

GLETRONICS, INC. warrants to the end purchaser that its pumps, switch and control unit products are free from defective materials and workmanship for the periods indicated below:

All parts and labor (excluding installation) for a period of:

- 3 years from the date of installation, when used intermittently as a sump pump

The defective product must be returned directly to the factory, postage prepaid with the original bill of sale or receipt to the address listed below. GLETRONICS, INC., at its option, will either repair or replace the product and return it postage prepaid.

### What is NOT Covered by this Warranty?

This warranty does not cover the cost or value of damaged property, including expressly any property that has been affected by water overflow, seepage or flooding. If GLETRONICS, INC. determines that a product is deemed defective under this warranty agreement, it will repair or replace the PRODUCT ONLY. GLETRONICS, INC. will not cover the cost to reinstall the product, nor will GLETRONICS, INC. pay the cost of having a plumber or contractor repair or replace the product.

GLETRONICS, INC. will not repair or replace a product that was installed incorrectly. A product shall be considered “installed incorrectly” when it deviates in any way from the instructions described in this manual.

This warranty does not cover product problems resulting from handling liquids hotter than 104 degrees Fahrenheit, handling inflammable liquids, solvents, strong chemicals or severe abrasive solutions; user abuse; misuse, neglect, improper maintenance, commercial or industrial use; improper connection or installation, damages caused by lightning strikes; excessive surges in AC line voltage; water damage to the controller; other acts of nature, or failure to operate in accordance with the enclosed written instructions.

### How to Obtain Warranty Service

Within thirty (30) days of the product’s defective performance, the unit must be shipped, freight prepaid, or delivered to GLETRONICS, INC. to provide the services described hereunder in either its original carton and inserts, or a similar package affording an equal degree of protection. Products not received by GLETRONICS, INC. at the address indicated below within thirty (30) days of the product’s defective performance will not be considered for warranty service. Products received after three (3) years from the date of purchase, fall outside of the timeframe for warranty service and will not be eligible for warranty service. The product must be returned to GLETRONICS, INC. for inspection in order to be considered for warranty service. If the product is not returned to GLETRONICS, INC. or the product is inspected by any person, plumber, contractor or business other than GLETRONICS, INC., this warranty shall no longer be valid. Prior to defective operation, the unit must not have been previously altered, repaired or serviced by anyone other than GLETRONICS, INC., or its agent; the serial number on the unit must not have been altered or removed; the unit must not have been subject to accident, misuse, abuse or operated contrary to the instructions contained in the accompanying manual. The dealer’s dated bill of sale, or installer’s invoice must be retained as evidence of the date of purchase and to establish warranty eligibility.

### Where are Products Sent for Warranty Service?

Glentronics, Inc., 645 Heathrow Drive, Lincolnshire, IL 60069

### How Can I Obtain More Information?

By calling 800-991-0466

## CHECK OUT THIS OTHER PHCC PRO SERIES PRODUCT

### WATER ALARM

#### *Minimize the risk of water damage*

You can detect leaks before they become bigger problems by placing a water alarm wherever there is a risk of water damage...in the utility room, laundry room, kitchen, bathroom or basement. The alarm will sound when as little as 1/32" of water reaches the sensor.

